

BULLY

INSTALLATION INSTRUCTIONS

AS-500S

WARNING :

- * Before you start installing ,read these instructions and make sure you understand them.
- * Do not install this product to your vehicle if the vehicle's body metal is rusted or otherwise damaged.
- * Before drilling any holes, be sure the area is clear of any obstacle such as fuel lines, brake lines, wire harnesses, A/C lines, etc. Be careful not to damage the painted body area.
- * Do not modify step or installation hardware. Use step only on vehicles listed on application chart. Install aluminum steps following these instructions only
- * Use steps to enter and exit vehicle only.

IMPORTANT: Bully assumes no liability for any damage or injury caused by customer's failure to adhere to the warnings and the directions of this instructions.

WARNING:
BEFORE YOU START INSTALLING, READ THESE INSTRUCTIONS CAREFULLY AND MAKE YOU UNDERSTAND THEM BEFORE YOU BEGIN.

READ WARNING NOTICE ON BACK SIDE OF INSTRUCTIONS BEFORE BEGINNING INSTALLATION







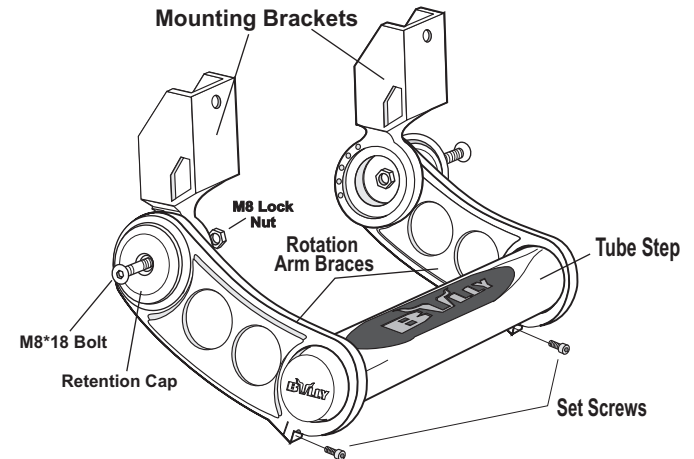



Tools Required:

- | | | | |
|--------------------|----------------|-----------------------|----------------------|
| Angled Power Drill | 3/8" Drill bit | Phillips Screw Driver | 14mm socket |
| 1/8" Drill bit | 1/4" Ratchet | 10mm socket | 13mm open end wrench |
| 5/16" Drill bit | 3/8" Ratchet | 13mm socket | 14mm open end wrench |

PARTS DIAGRAM



MOUNTING HARDWARE

 5/16" x 1 1/8" Bolt X4	 5/16" x 2" Bolt X2	 5/16" x 18 Nut X4	 5/16" Washer X8	 Sheet Metal Screw X4	 "L" Shaped Spacer X2	 "C" Shaped Bracket X2	 Plastic Wedge Spacer X2	 M8*18 Bolt X2	 M8 LOCK NUT X2
---	--	---	---	---	--	--	--	--	---

BODY TYPES

BEFORE STARTING THE INSTALLATION PROCESS
Identify your vehicle's body type to one of the diagrams below

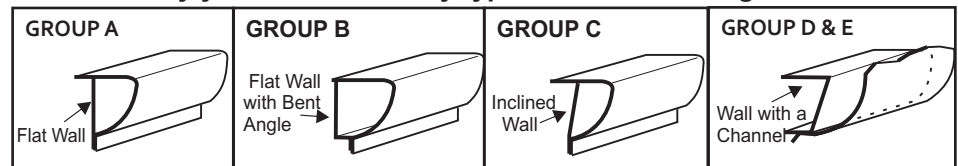

Follow the proper installation instructions for your vehicle type on the following pages

 (800)-237-7560
WWW.BULLYTRUCK.COM
 For Technical Assistance

(STEP 1) INSTRUCTIONS FOR GROUP A, B & C

1. For the proper position to mount the steps, the center of the steps should be in line with the front edge of your seat's frame. Make sure that your step's Mounting Brackets are mounted up against a flat surface under your rocker panel.
2. Mark a vertical line along the center of the step onto the pinch weld flange of the rocker panel. ****Note:** Some truck models may require this flange to be bent into a vertical position (see detail on Fig. A inserted diagram). Measure 6" from each side of your marked centerline and mark two more lines on the pinch weld flange. The dimension between the two outside lines should be 12" apart.
3. On each of your two outside lines, mark a point at the vertical center of the flange. Drill a 3/8" hole on these 2 points. ****Note:** Make sure that the area is clear of any obstacles before drilling. Use a center punch and 1/8" bit to drill a pilot hole first to achieve the best results.
4. Place the Mounting Brackets up onto their mounting positions (logo side facing out), push the Mounting Brackets up as far as it will go so the bottom of the pinch weld flange is against the bottom of the Mounting Bracket's mounting surface and mark a point onto each of the Mounting Brackets through the holes you've just drilled.
5. Remove the Mounting Brackets and drill out a 3/8" hole on the marked points.

NEXT FOLLOW THE INSTRUCTIONS BELOW ACCORDING TO YOUR PARTICULAR BODY GROUP TYPE

FOR GROUP A: (See Fig. 1)

- a. Assemble the 2 Mounting Brackets onto your vehicle, use 5/16" bolts, nuts and washers with 13 mm wrench and socket to tighten them firmly onto the pinch weld flange.
- b. Use an angled drill to gain access and drill a 1/8" hole through the body metal by using the top 1/4" hole on the Mounting Bracket as a guide. Install and tighten with the 1" sheet metal screws in the upper hole, then you're ready to move forward to **STEP 2** on the back page of this installation manual.

FOR GROUP B: (See Fig. 2)

- a. Assemble the 2 Mounting Brackets onto your vehicle, insert the 5/16" bolts with washers through the holes onto the pinch weld flange, install the "U" shape spacers then the Mounting Brackets and firmly tighten together with the 5/16" washers and nuts.
- b. Use an angled drill to gain access to and drill a 1/8" hole through the body metal by using the top 1/4" hole on the Mounting Brackets as a guide. Install and tighten with the 1" sheet metal screws into the upper holes, then you're ready to move forward to **STEP 2** on the back page of this installation manual.

FOR GROUP C: (See Fig. 3)

- a. Assemble the 2 Mounting Brackets onto your vehicle, insert the 5/16" bolts with washers through the hole onto the pinch weld flange, place the two plastic wedges between the upper portion of the Mounting Brackets and body metal, then hand tighten the Mounting Brackets on with the 5/16" washers and nuts.
- b. Move the wedges up and down until the flat face of the Mounting Brackets are exactly vertical, mark the location of the Mounting Brackets 1/4" hole onto the wedges while holding the Mounting Brackets in place. Remove the wedges, drill out a 1/4" hole at the marked locations.
- c. Place the drilled wedges back in place, drill a 1/8" hole through the body metal by going through the Mounting Brackets and the wedge together, use the 1" sheet metal screws to tighten the Mounting Brackets, the wedge and body metal together. Use a 13mm wrench and socket to tighten the 5/16" bolts and nuts firmly onto the pinch weld flange. Now you're ready to move forward to **STEP 2** on the back page of this installation manual.

(STEP 2) INSTRUCTIONS FOR ALL GROUPS

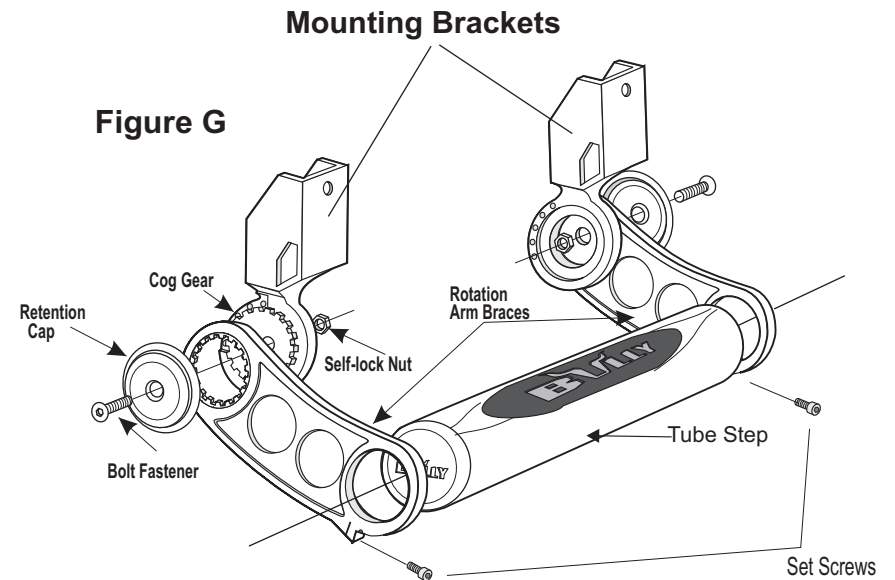

1. Place one of the Rotation Arm Brace up against the Cog Gear of the Mounting Bracket, rotate the arm to determine your preferred height adjustment then secure it together with the Retention cap using the (M8*18 Bolt and M8 Nylon Lock Nut). Insert the Tube Step as shown and fasten together with the remaining Rotation Arm Brace onto the corresponding Cog Gear.
2. Make sure that the Rotation Arm Braces holding your Tube Step is approximately 12" apart. Rotate your step pad so it's facing upward and level with the ground before tightening with the two set screws located on the ends of the Rotation Arm Braces.

(STEP 1) INSTRUCTIONS FOR GROUP D :

1. For the proper position to mount the steps, the center of the steps should be in line with the front edge of your seat's frame. Make sure that your step's Mounting Brackets are mounted up against a flat surface under your rocker panel.
2. Mark a vertical line on the center position of your step onto the underside of your rocker panel's pinch weld flange. Measure 6" out on both sides from your marked center line and mark two more lines onto your pinch weld flange. The dimension between the two outside lines should be 12" apart.
3. Along the 2 outside lines, measure 1/2" (measure 1/4" for Suburban) inward from the inside edge of the pinch weld and mark a point on each of the two lines, then drill a 3/8" hole at these two points. (**Note: Make sure that the area is clear of obstacles before drilling) Use a center punch and 1/8" bit to drill a pilot hole first to achieve the best results. For Suburban: Be sure the air conditioning lines are out of the drilling path (see Fig. D-3).
4. Position the "C" Bracket against the Mounting Braces (see Fig. D-2). Center the front top hole of the "C" Bracket together with the top hole on your Mounting Brace, then mark the bottom hole on your Mounting Brace through the bottom hole of the "C" Bracket. Drill a 3/8" hole through the marked point on your Mounting Brace. Repeat this procedure to all (4) Mounting Braces.
5. Place the "C" Bracket up inside the rocker panel (see Fig. D-1), carefully maneuver the brackets into the required position. Mark a point onto the bottom of the "C" Bracket through the hole you previously drilled on your rocker panel, remove the bracket and drill a 3/8" hole at the marked point on your "C" Bracket. (repeat this procedure on all "C" Bracket)
6. Attach the "C" Bracket to your rocker panel, use the 5/16" bolts, nuts and washers and hand tighten them together onto your pinch weld flange. Mark a point on the vehicle's body metal up through the top hole of your "C" Bracket. Remove the bracket to prepare for drilling.

NOTE: **DO NOT DRILL** Before Completing This Next Step Important.

7. (Refer to Fig. D-5) Remove the plastic door entry cover & move the wire harness out of the way before proceeding.
8. Drill a 1/8" pilot hole up into the marked points on your rocker panel.
9. Mount "C" Bracket onto your rocker panel, use the 5/16" bolts, nuts and washers with 1/2" wrench and socket to tighten them securely together onto the pinch weld flange. Screw the 1" sheet metal screw up through the top hole of the "C" Bracket into the body metal of your rocker panel.
10. Install the Step Mounting Braces onto your "C" Bracket. Apply the 1" sheet metal screws through the upper holes, apply 5/16" bolts, washers and nuts through the lower holes to secure the Mounting Braces to the "C" Brackets. Use the proper tools to tighten all the screws, bolts and nuts firmly. (see Fig. D-1)
11. Reinstall the plastic door entry cover, make sure the screws will not pierce the wires when putting back the harness.

GROUP D

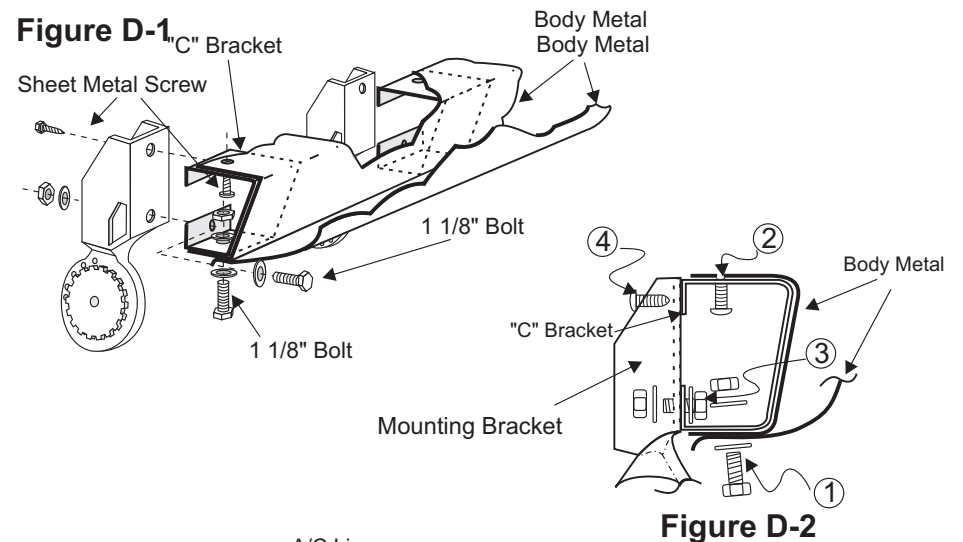

Figure D-2

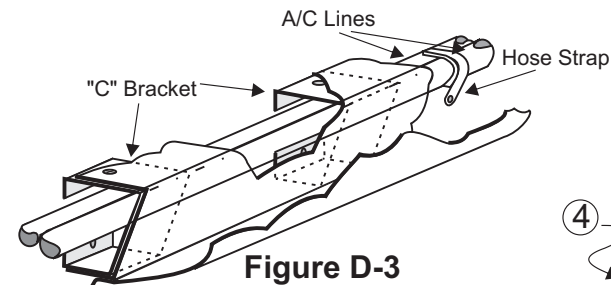

Figure D-3

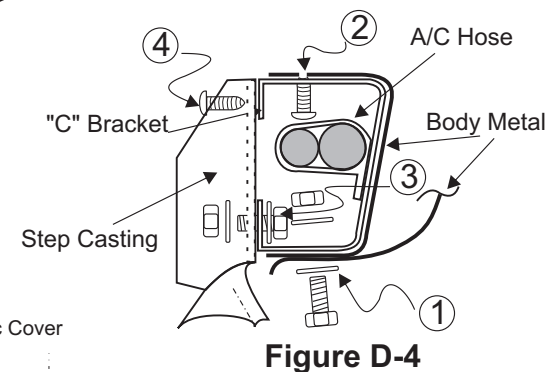

Figure D-4

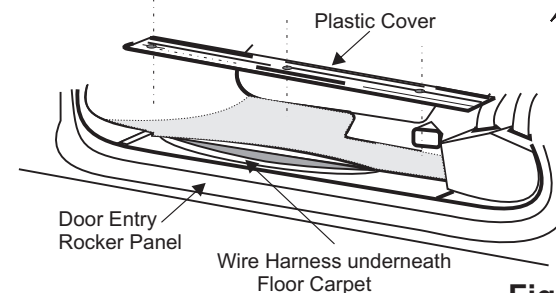
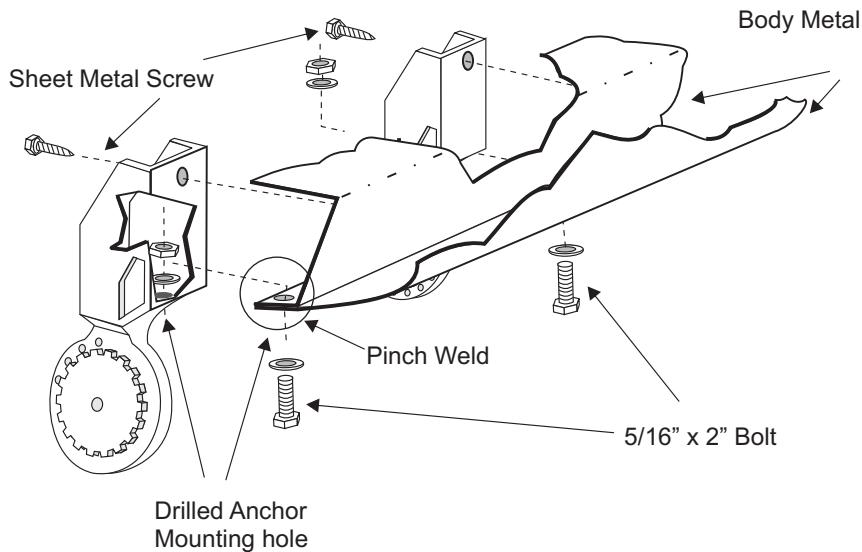

Figure D-5

(STEP 1) INSTRUCTIONS FOR GROUP B

1. For the proper position to mount the steps, the center of the steps should be in line with the front edge of your seat's frame. Make sure that your step's Mounting Brackets are mounted up against a flat surface under your rocker panel.
2. Mark a vertical line along the center of the step onto the pinch weld flange of the rocker panel. ****Note:** Some truck models may require this flange to be bent into a vertical position (see detail on Fig. A inserted diagram). Measure 6" on each side of your marked line and mark two more lines on the pinch weld flange. The dimension between the two outside lines should be 12" apart.
3. On each of your two outside lines, mark a point at the vertical center of the flange. Drill a 3/8" hole on these 2 points. ****Note:** Make sure that the area is clear of any obstacles before drilling. Use a center punch and 1/8" bit to drill a pilot hole first to achieve the best results.
4. Place the Mounting Brackets up onto their mounting positions (cog gear facing out), push the Brackets inward as far as it will go so the bottom of the pinch weld flange is against the bottom of the Bracket's mounting surface and mark a point onto each of the Brackets through the holes you've just drilled.
5. Remove the Brackets and drill out a 3/8" hole on the marked points.
6. Assemble the 2 Mounting Brackets onto your vehicle, use 5/16" bolts, nuts and washers with 13mm wrench and socket to tighten them firmly onto the pinch weld flange.
7. Use an angled drill to gain access and drill a 1/8" hole through the body metal by using the top 1/4" hole on each Mounting Bracket as a guide. Install and tighten with the 1" sheet metal screws in the upper hole, then you're ready to move forward to STEP 2 of this installation manual.



6.

GROUP A

Figure 1

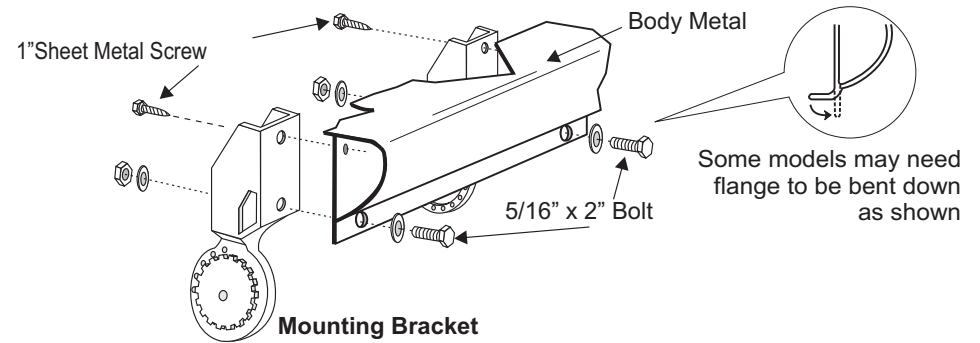

GROUP B

Figure 2

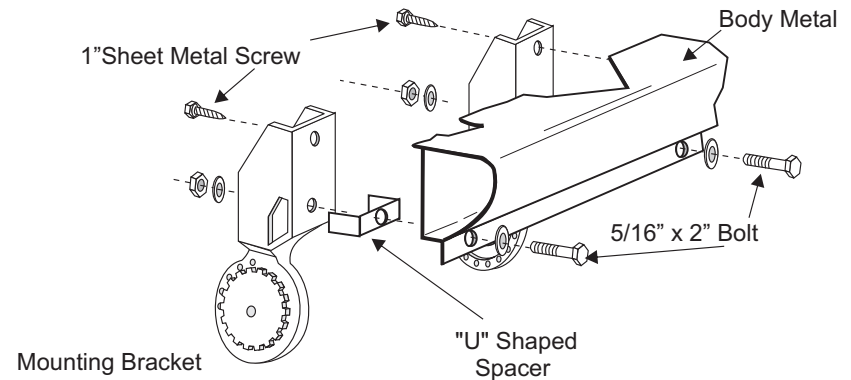

GROUP C

Figure 3

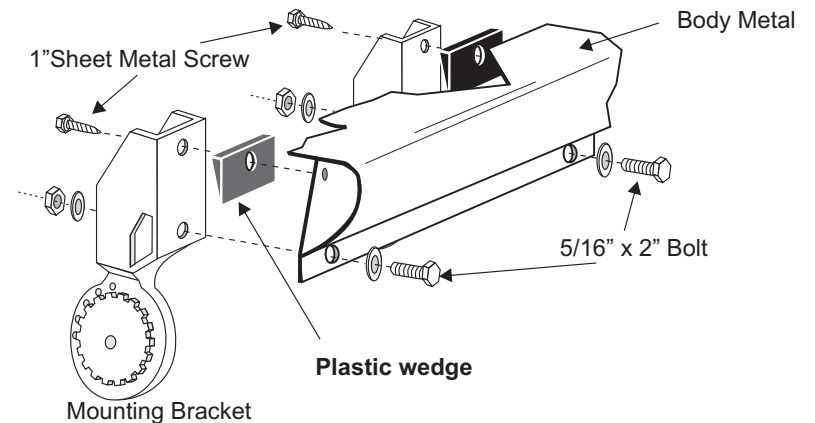

3.